

SAINLOGIC WS-0835 Plus Professional WIFI Wireless Weather Station User Manual

1.Introduction

Thank you for your purchase of the WS-0835 Plus Professional WIFI Wireless Weather station. The following user guide provides step by step instructions for installation, operation and troubleshooting.

2.Warnings

⚠ Warning: Any metal object may attract a lightning strike, including your weather station mounting pole. Never install the weather station in a storm.

⚠ Warning: Installing your weather station in an elevated location may result in injury or death. Safety goes first. Make sure your setup and preparation is secure, and take no risks.





3.Getting Started

The WS-0835 Plus weather station consists of a display console (receiver), a sensor array with Integrated Outdoor Transmitter and mounting hardware

Parts List

The weather station consists of the following parts (as referenced in Figure 1).

QTY	Item	Image
1	Display Console Frame Dimensions (LxHxW): 5.3X 1 X 3.7in LCD Dimensions (LxW): 4.3 x 3in	

QTY	Item	Image
1	Integrated Outdoor Transmitter Dimensions (LxHxW): 13 x 6 x 11in	
1	Foot Mounting (with pole insert) Dimensions: 3 x 4 x 1 ½”	
1	Mounting Bracket Back Plate (pole mount) Dimensions: 3 x 3 x 1 ”	
1	Mounting Pole Dimensions: 12 x 1 ½ x 1”	





QTY	Item	Image
2	Pole mounting nuts (M3) / bolts Ø3)	
4	Pole mounting nuts (M5) / bolts (Ø5)	
4	Tapping screws	
1	Manual	
1	Power Adapter	

Figure 1

3.2 Recommend Tools

- Precision screwdriver (for small Phillips screws)
- Compass or GPS (for wind direction calibration)

- Adjustable Wrench
- Hammer and nail for Foot Mounting.

3.3 Sensor Assembly Set Up

The following illustration shows the full segment for Thermo-Hygrometer, WIND and RAIN transmitter purposes only, as shown in Figure 2.

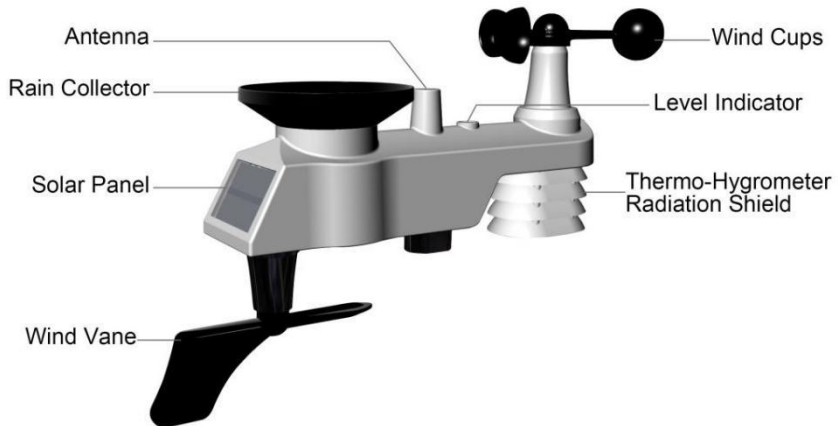

Figure 2

3.3.1 Insert batteries into the transmitter. Locate the battery door on the transmitter, push and open the battery compartment, as show in Figure 3.

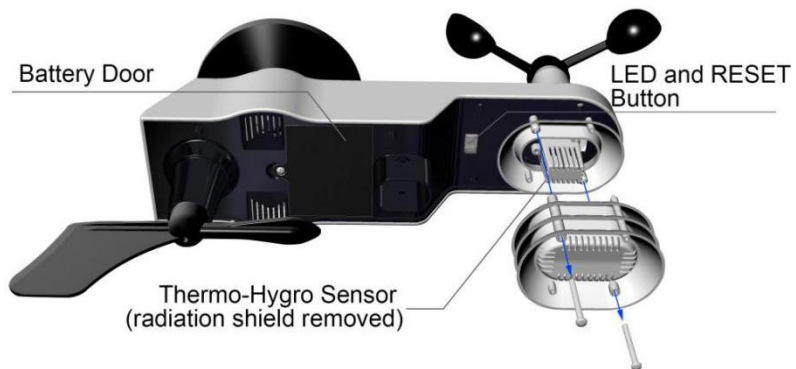

Figure 3

Remove the battery door on the back of the sensor by removing the set screw, as shown in Figure 4.



Figure 4

Inserting 3xAA batteries in the battery compartment, as show in Figure 5.

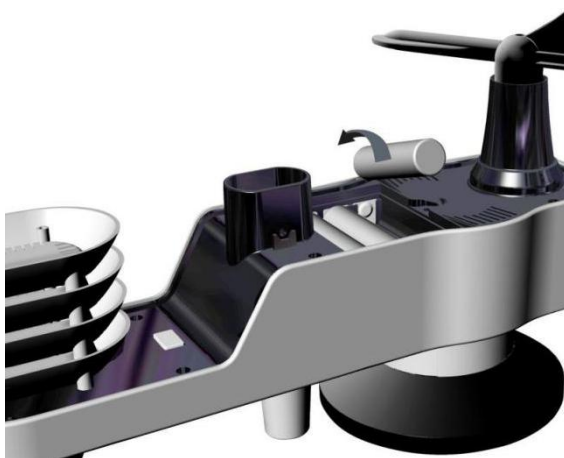





Figure 5

Close the battery cover. Make sure the gasket (around the battery compartment) is properly seated in its place prior to closing the door. Tighten the set screw.

 **Note:** Do not install the batteries backwards. You can permanently damage the sensors. The solar panel does not charge the batteries, so rechargeable batteries are not needed or recommended.

 **Note:** We recommend installing Lithium AA batteries for sensors. The sensor LED indicator will light for 3 seconds, and then flash once per 16 seconds thereafter. Each time it flashes, the sensor is transmitting data.

Place the battery cover and push it to close the compartment.

 **Note:** If the sensor does not power up after inserting the batteries, press the reset button shown in Figure 6.

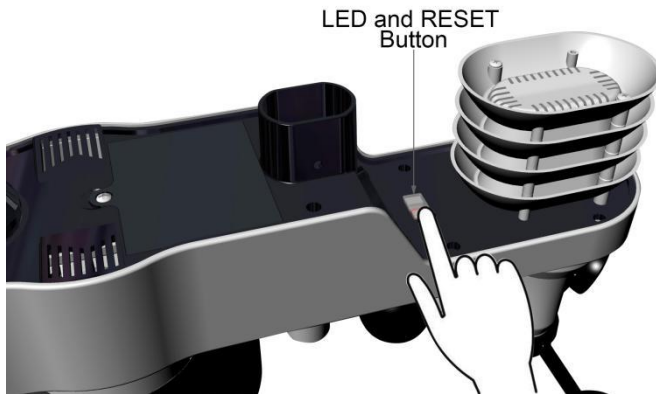



Figure 6

3.4. Display Console

3.4.1. Display Console Layout

The display console layout is shown in Figure 7

 **Note:** The following illustration shows the full segment LCD display for description purposes only and will not appear like this during normal operation.

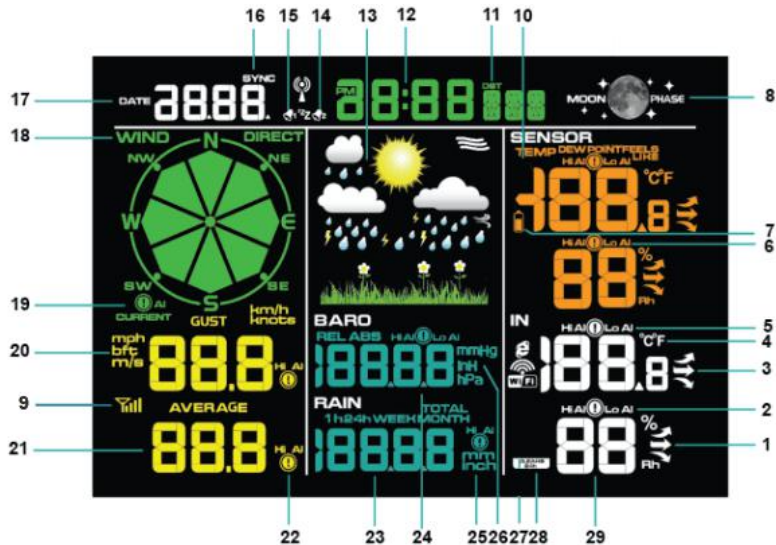



Figure 7

- | | |
|---|--|
| 1. Indoor humidity change indication | 15. Time Alarm 2 |
| 2. Indoor humidity HI/LO alarm icon | 16. 16. Time SYNC |
| 3. Indoor temperature change indication | 17. DATE |
| 4. Temperature units ($^{\circ}\text{F}$ or $^{\circ}\text{C}$) | 18. Wind direction |
| 5. Indoor temperature HI/LO alarm icon | 19. Wind speed units of measure |
| 6. Outdoor humidity HI/LO alarm icon | 20. Wind speed Gust display |
| 7. Battery low voltage prompt | 21. Wind speed average display |
| 8. Moon phase | 22. Wind speed average HI alarm icon |
| 9. Reception icon | 23. Rainfall display (1h, 24h, week, month, total) |
| 10. Outdoor temperature mode | 24. Pressure (REL and ABS) display |
| 11. Daylight Saving Time | 25. Rainfall units of measure |
| 12. Time | 26. Pressure units of measure |
| 13. Weather tendency indicator | 27. WIFI network |
| 14. Time Alarm 1 | 28. 24hour for clear |
| | 29. Indoor humidity display |

3.4.2. Display Console Set Up

It is recommended to plug in the power supply to reduce the battery consumption and extend the service life.

 **Note:** The sensor array must be powered and updating before powering up the console, or the console will time out searching for the sensors. Power the console last.

Make certain the weather station sensor array is at least 10' away from the console and within 100' of the console. If the weather station is too close or too far away, it may not receive a proper signal.

Remove the battery door on the back of the display, as shown in Figure 8. Insert three AAA (alkaline or lithium) batteries in the back of the display console. The display will beep once and all of the LCD segments will light up for a few seconds to verify all segments are operating properly.



 **Note:** The character contrast is best from a slightly elevated viewing angle.



Figure 8

Replace the battery door, and fold out the desk stand and place the console in the upright position.

The unit will instantly display indoor temperature, humidity, pressure, tendency, moon phase, and time. The wind speed, wind gust, wind direction, rain, outdoor temperature and humidity will update on the display within a few minutes. Do not Press any menu buttons until the outside transmitter report in, otherwise the outdoor sensor search mode will be terminated. When the outdoor transmitter data has been received, the console will automatically switch to the normal mode from which all further settings can be performed.

While in the search mode, the remote search icon  will be constantly displayed.

 **Note:** The power adapter is intended to be correctly oriented in a vertical or floor mounted position. The prongs are not designed to hold the plug in place if it is plugged into a ceiling, under-the-table or cabinet outlet.



Figure 9

1: Fold out the desk stand and see **DC jack** on the left ; as shown in Figure 10

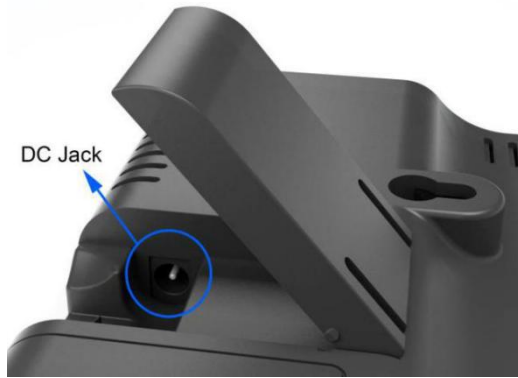

Figure 10

2: Insert the **DC plug** correctly ; as shown in Figure 11

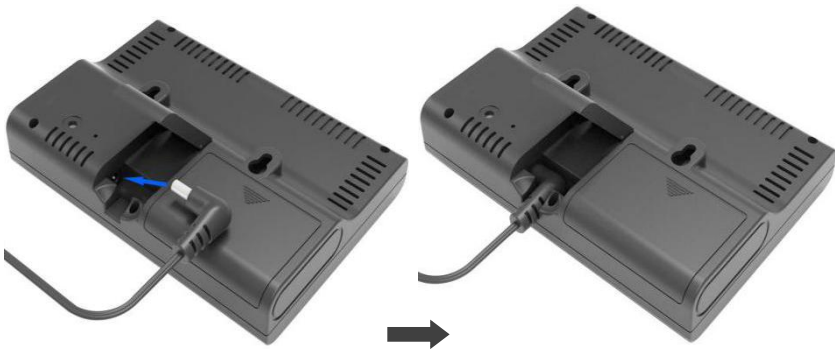

Figure 11

3: If you want to put it on a table or cabinet, opened the desk stand and turn the **DC plug** up until 90 degrees; as shown in Figure 12



Figure 12

4: If you want to hang on the wall, turn the **DC plug** down until 0 degrees and closed the desk stand; as shown in Figure 13



Figure 13

 **Note:** If the power adapter is plugged in, **BL ON** will display in the time area for three seconds when powered up. Conversely, if the power adapter is not plugged in, **BL OFF** will be displayed.

3.4.3. Sensor Operation Verification

The following steps verify proper operation of the sensors prior to installing the sensor array.

1. Verify proper operation of the rain gauge. Tip the sensor array back and forth several times. You should hear a “clicking” sound within the rain gauge. Verify the rain reading on the display console is not reading 0.00. Each “click” represents 0.01 in of rainfall.
2. Verify proper operating of the wind speed. Rotate the wind cups manually or with a constant speed fan. Verify the wind speed is not reading 0.0.
3. Verify proper operation of the indoor and outdoor temperature. Verify the indoor and outdoor temperature match closely with the console and sensor array in the same location (about 9.8 ft apart). The sensors should be within 4°F (the accuracy is $\pm 2^\circ\text{F}$). Allow about 30 minutes for both sensors to stabilize.
4. Verify proper operation of the indoor and outdoor humidity. Verify the indoor and outdoor humidity match closely with the console and sensor array in the same location (about 9.8 ft apart). The sensors should be within 10% (the accuracy is $\pm 5\%$). Allow about 30 minutes for both sensors to stabilize.

4. Weather Station Installation

4.1. Pre Installation Check. Before installing your weather station in the permanent location, we recommend operating the weather station for one week in a temporary location with easy access. This will allow you to check out all of the functions, insure proper operation, and familiarize you with the weather station and calibration procedures. This will also allow you to test the wireless range of the weather station.

4.2. Location Survey

Perform a site survey before installing the weather station. Consider the following:

1. You must clean the rain gauge once per year and change the batteries every year. Provide easy access to the weather station.
2. Avoid radiant heat transfer from buildings and structures. In general, install the sensor array at least 5' from any building, structure, ground, or roof top.
3. Avoid wind and rain obstructions. The rule of thumb is to install the sensor array at least four times the distance of the height of the tallest

obstruction. For example, if the building is 20' tall, install 4 x (20 – 6)' =56' away. Use common sense. If the weather station is installed next to a tall building, the wind and rain will not be accurate.

4. **Wireless Range.** The radio communication between receiver and transmitter in an open field can reach a distance of up to 300 ft, providing there are no interfering obstacles such as buildings, trees, vehicles, high voltage lines. Wireless signals will not penetrate metal buildings. Most applications will only reach 100 ft due to building obstructions, walls and interference.

5. Radio interference such as PCs, radios or TV sets can, in the worst case, entirely cut off radio communication. Please take this into consideration when choosing console or mounting locations.

4.3. Best Practices for Wireless Communication

Wireless communication is susceptible to interference, distance, walls and metal barriers. We recommend the following best practices for trouble free wireless communication.

1. **Electro-Magnetic Interference (EMI).** Keep the console several feet away from computer monitors and TVs.

2. **Radio Frequency Interference (RFI).** If you have other 433 MHz devices and communication is intermittent, try turning off these other devices for troubleshooting purposes. You may need to relocate the transmitters or receivers to avoid intermittent communication.

3. **Line of Sight Rating.** This device is rated at 300 ft line of sight (no interference, barriers or walls) but typically you will get 100 ft maximum under most real-world installations, which include passing through barriers or walls.

4. **Metal Barriers.** Radio frequency will not pass through metal barriers such as aluminum siding. If you have metal siding, align the remote and console through a window to get a clear line of sight.

The following is a table of reception loss vs. the transmission medium. Each “wall” or obstruction decreases the transmission range by the factor shown below.

Medium	RF Signal Strength Reduction
Glass (untreated)	5-15%
Plastics	10-15%

Wood	10-40%
Brick	10-40%
Concrete	40-80%
Metal	90-100%

5. Final Installation of Sensor

Integrated outdoor transmitter installation.

Professional Wireless Weather Station can be used in both the Northern and Southern Hemispheres.

Prior to installation, you will need to calibrate the wind direction.

5.1. Northern Hemispheres (NOR).

The cardinal directions (N, S, E, W) molded on the body of the outdoor sensor are indicators for the Northern Hemisphere only.

Step 1: There is a “S” indicator on the wind vane that indicates South, as shown in Figure 14. Align this “S” marker in the direction of South.

Step 2: Console operation is set to Northern Hemispheres (**NOR** in the time area) in Location division.



Note: There are four alphabet letter of “N”, “E”, “S” and “W” around the wind direction, representing for the direction of North, East, South and West. Wind direction sensor has to be adjusted so that the directions on the sensor are matching with your real location. Permanent wind direction error will be introduced when the wind direction sensor is not positioned correctly during installation.



Northern Hemispheres

Figure 14

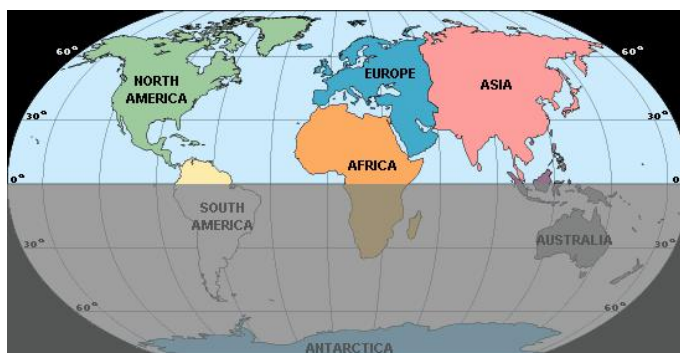

Southern Hemispheres

5.2. Southern Hemispheres (SOU).

For Southern Hemisphere installations, ignore these(N, S, E, W) and face **the solar panel to the North** (and in a sunny position) when installing the Integrated outdoor transmitter.

Step 1: Install the Integrated outdoor transmitter and face the solar panel North.

Step 2: Console operation is set to Southern Hemispheres (**SOU** in the time area) in Location division.

 **Note:** Console has to be location division setting so that the directions on the sensor are matching with your real location. Permanent wind direction error (read approximately 180°) will be introduced when the wind direction sensor is not positioned correctly during installation.

Fasten the integrated transmitter to mounting pole brackets with foot-mounting, two $\varnothing 3$ bolts and M3 nuts, as shown in Figure 15



Figure 15

Tighten the mounting pole to your mounting pole(purchased separately) with the four $\varnothing 5$ Bolts and M5 Nuts assembly, or fix on the wall with four tapping screw, as shown in Figure16.

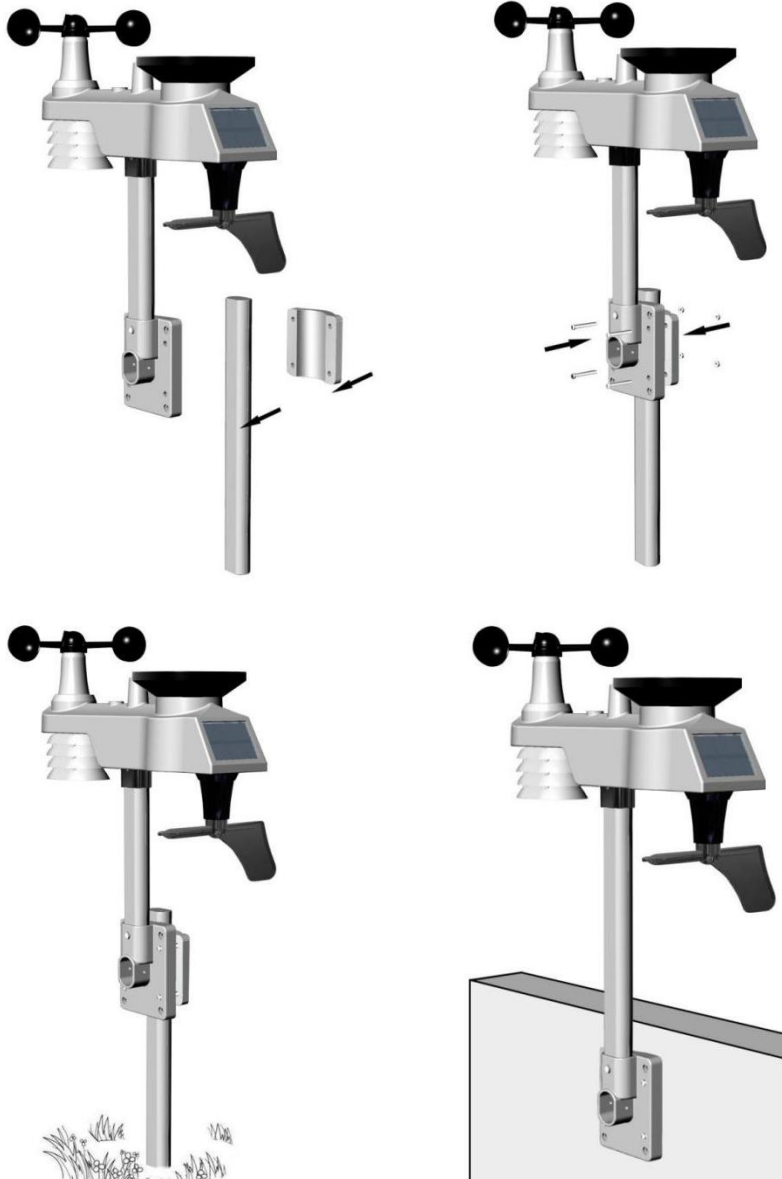

Figure 16

6. Low Battery Icon

A low battery indicator icon is shown in the display window for Integrated outdoor transmitter. When the low battery icon appears (the battery voltage is lower than 3.6V), replace the batteries in the sensor with fresh batteries. Be sure to never mix old and new batteries, and never mix battery types such as alkaline and lithium together.

7. Console Operation



Note: The console has five keys for easy operation: **SET** key and **ALARM** key on the right side, **MIN/MAX/-** key, **SNOOZE/LIGHT** and **CHANNEL/+** key on the top.

7.1. Quick Display Mode



Note: To exit the Quick Display Mode at any time, press the **SNOOZE** button of the display console.

While in Normal Mode, press (do not hold) the **SET** key to enter the Quick Display Mode as follows:

- once for time/second/date, time/week/date and time/week/year
- twice for rainfall.
- three for pressure
- four for outdoor dew point temperature

1. **Time, Time/Week and Date.** Press the **CHANNEL/+** or **MIN/MAX/-** key to toggle between time/second/date, time/week/date and time/week/year.

2. **Rainfall.** Press the **CHANNEL/+** or **MIN/MAX/-** key to toggle between 1h, 24h, week, month and total.

To clear the total rain, press the **CHANNEL/+** or **MIN/MAX/-** button until total rain is displayed. The total rain will flash. Press and hold the **SET** button for three seconds until total rain reads 0.0.

3. **Absolute Pressure and Relative Pressure.** Press the **CHANNEL/+** or **MIN/MAX/-** key to toggle between absolute pressure and relative pressure.

4. **Outdoor dew point .** Press the **CHANNEL/+** or **MIN/MAX/-** key to toggle between temperature, dew point and feels like

7.2. Set (Program) Mode

While in Normal Mode, Press **and hold** the **SET** key for at least three seconds to enter the Set Mode. The first setting will begin flashing. You can press the **SET** key again to skip any step, as defined below.



Note: In the Set mode, press the [+] key or [-] key to change or scroll the value. Hold the [+] key or [-] key for three seconds to increase/decrease rapidly.



Note: To exit the Set mode at any time, press the **SNOOZE** button of the display console.

1. **12/24 Hour Format (default: 12h):** Press the **SET** key again to adjust the 12/24 hour format setting (FMT). Press the [+] key or [-] key to change between 12 hour and 24 hour format.
2. **Change Hour.** press the **SET** key again to set the hour. Press the [+] key or [-]key to adjust the hour up or down. Note the PM icon is present during afternoon hours.
3. **Change Minute.** Press the **SET** key again to set the minute. Press the [+] key or [-] key to adjust the minute up or down.
4. **Date Format (default: MM-DD):** Press the **SET** key again to enter the day/month format mode. Press the [+] key to switch between **M-D, D-M.**
5. **Change Month.** Press the **SET** key again to set the calendar month. Press the [+] key or [-] key to adjust the calendar month.
6. **Change Day.** Press the **SET** key again to set the calendar day. Press the [+] key or [-] key to adjust the calendar day.
7. **Change Year.** Press the **SET** key again to set the calendar year. Press the [+] key or [-] key to adjust the calendar year.
8. **Max/Min Clearing (default: ON).** Press the **SET** key again to set the max/min clearing mode (CLR). The Max/Min can be programmed to clear daily (at midnight) or manually. Press the [+] key or [-] key to switch between “Clears 24h” and Clears Manually.
9. **Temperature Units of Measure (default: °F):** Press the **SET** key again to change the temperature units of measure (the **UNITSET** icon will be displayed). Press the [+] key or [-] key to switch between °F and °C units of measure.
10. **Wind Speed Units of Measure (default: mph).** Touch the **SET** key again to change the wind speed units of measure . Touch the [+] key or [-] key to toggle the wind speed units between m/s,bft,knots,mph or bft.

11. **Rainfall Units of Measure (default: in).** Touch the **SET** key again to change the Rainfall units of measure. Touch [+] key or [-] key to toggle the rainfall units between mm and in.
12. **Barometric Pressure Display Units(default: inHg).** Press the **SET**key again to change the pressure units of measure. Press the [+] key or [-] key to toggle the pressure units between mmHg, inHg or hPa.
13. **Pressure Threshold Setting (default level 2).** Press the **SET** key again adjust the Pressure threshold setting. Press [+] key or [-] key to adjust the pressure threshold setting up or down.
14. **Weather Forecast Icon Setting (default: partly cloudy).** Press the **SET** key again to set the weather forecast icon initial conditions (based on the current weather conditions). Press the [+] key or [-] key to toggle weather icons between sunny, partly cloudy, cloudy, or rainy.
15. **Time SYNC(default:ON).**Press the SET key again to set the network time sync. Press the [+] key or [-] key to switch between SYNCtime ON and SYNCtime OFF of measure.
16. **Location division.(default: Northern Hemisphere)** Press the **SET** key again to change the location division. Press the [+] key or [-] key to toggle the sunlight units Northern Hemisphere (NOR)or Southern Hemisphere(SOU).(refer to 5.0 Final Installation of Integrated outdoor transmitter)

7.3. Sensor Search Mode

If Outdoor sensor loses communication, dashes (--.-) will be displayed. To reacquire the lost signal, press and hold the **CH/+** button for 3 seconds to enter the sensor search mode.

7.4. Reset Min/Max record



Note: The minimum and maximum value of all channels will be cleared in the reset mode.

In normal mode, Press (do not hold) the **MIN/MAX/-**key, and the **MAX** icon will be displayed. Press the **SET** key to view rainfall (1h, 24h, week or month) , pressure (ABS or REL) max value ,outdoor temperature (temperature, dew point or feels like).

Next, press and hold the **MIN/MAX/-** key for three seconds (and the **CLR** character is flashing in time area) to clear the rainfall, wind speed, wind gust, pressure, temperature and humidity maximum values. The maximum values will now display the current values.

Press the **MIN/MAX/-** key again (do not hold), and the **MIN** icon will be displayed. Press the **SET** key to view pressure (ABS or REL) min value, pressure (ABS or REL) min value, outdoor temperature (temperature, dew point or feels like).

Next, Press and hold the **MIN/MAX/-** key for three seconds (and the **CLR** character is flashing in time area) to clear the pressure, temperature and humidity minimum values. The minimum values will now display the current values.

Press the **SNOOZE** key to exit the min/max checking and cleaning mode, return to normal display mode.

7.5. Snooze Mode

If the alarm sounds, and you wish to silence the alarm, press the **SNOOZE** key, the backlight will turn on. The alarm icon will continue to flash and the alarm will silence for five minutes. Press any key (**MIN/MAX/+**, **SET**, **ALARM**, **CHANNEL/+**) to permanently exit the **Snooze** mode.

7.6. Back light Mode

If the LED is off, Press the **SNOOZE** button once. The backlight will turn on for five seconds, and if no operation is performed for three seconds, the backlight will turn off.

The backlight operation is different when operating on batteries to save power.

ADJUSTABLE BACKLIGHT BRIGHTNESS

There are 3 levels of brightness of backlight. When the backlight is on press **SNOOZE** key to switch between the 3 levels.

Press and hold the **LIGHT** key for two seconds, and the backlight will turn on permanently, and display **BL ON** icon will be displayed for three seconds in the time field.

To turn off the backlight at any time, Press and hold the **SNOOZE/LIGHT** key for two seconds, and **BL OFF** icon will be displayed for three seconds in the date field.



Note: If plugged into AC power, the backlight will remain on. It is not recommended leaving the backlight on for a long period of time when operating on batteries only, or the batteries will run down quickly.

8. Alarm Mode

The weather station includes the following alarms:

- Time(Alarm1 and Alarm2)
- Wind Gust
- Wind Average
- Outdoor Temperature
- Outdoor Humidity
- Outdoor Feels Like Temperature
- Outdoor Dew Point
- Hourly Rainfall
- 24 Hour Rainfall
- Absolute Pressure
- Relative Pressure
- Indoor Temperature
- Indoor Humidity

8.1. Alarm Operation

When an alarm condition is exceeded, the alarm icon will flash  (visual) and the alarm beeper will sound (audible). To silence the beeper, press any key.

8.2. Viewing the High and Low Alarms

To view the current alarm settings, press the **ALARM** key to enter the alarm mode. HI will be displayed in the time area. At the same time Alarm time parameters of out/indoor temperature/humidity, rain, feels like, wind gust, wind average, and dew point are displayed.

Press **ALARM** key again to view the LOW alarms along with the alarm clock time the same way HI alarms.

Press the **SNOOZE** key at any time to return to the normal mode.

8.3. Setting the Alarms

Press **ALARM** key to enter the alarm mode.

Next, Press and hold the **SET** key for three seconds. The first alarm parameter will begin flashing (alarm hour).

To save the alarm setting and proceed to the next alarm parameter, press(do not hold) the SET key.

To adjust the alarm parameter, Touch the [+] or [-] key to increase or decrease the alarm settings, or Touch and hold the [+] or [-] key for three seconds to increase or decrease the alarm settings rapidly.

Press the ALARM key to turn on (the alarm icon will appear) and off the alarm.

Press the SNOOZE key once at any time to return to the normal mode. After 30 seconds of inactivity, the alarm mode will time out and return to normal mode.

The following is a list of the individual alarm parameters that are set (in order):

1. Alarm hour(alarm 1)
2. Alarm minute(alarm 1)
3. Alarm hour(alarm 2)
4. Alarm minute(alarm 2)
5. Wind Gust high alarm
6. Wind Average high alarm
7. Outdoor temperature high alarm
8. Outdoor temperature low alarm
9. Outdoor humidity high alarm
10. Outdoor humidity low alarm
11. Outdoor feels like high alarm
12. Outdoor feels like low alarm
13. Outdoor dew point high alarm
14. Outdoor dew point low alarm

15. Rainfall (1h) high alarm
16. Rainfall (24h) high alarm
17. Absolute pressure high alarm(ABS)
18. Absolute pressure low alarm(ABS)
19. Absolute pressure high alarm(REL)
20. Absolute pressure low alarm(REL)
21. Indoor temperature high alarm
22. Indoor temperature low alarm
23. Indoor humidity high alarm
24. Indoor humidity low alarm



Note: To prevent repetitive alarming of humidity, there is a 4% tolerance band. For example, if you set the high alarm to 60% and silence the alarm, the alarm icon will continue to flash until the humidity falls below 56%, at which point, the alarm will reset and must increase above 60% to activate again.

8.4. Alarm and Command Key Beeper ON/OFF Mode

The beeper can be silenced for both alarms and key strokes.

In normal mode, press and hold the **ALARM** key for three seconds to toggle the beeper on or off (depending on the current setting).

The **BZ ON** (beeper on) or **BZ OFF** (beeper off) icon will appear in the time area for three seconds. Press and hold the **ALARM** key again for three seconds to toggle the **BZ ON** or **BZ OFF** command.

9. WiFi Connection Status

When the console successfully connects to your Wi-Fi router, the Wi-Fi signal icon  will appear on the LCD display(In front of the Indoor Temperature). If the Wi-Fi signal is not stable or the console is trying to connect to the router, the icon will flash. If the icon disappears, it means the console is not connected to the Wi-Fi router.



Note: If you own a dual band router (2.4 GHz and 5.0 GHz), make sure you connect to the 2.4 GHz band, otherwise it will fail to connect the weather station to WiFi.

10. Time Server Sync Status

After the console has connected to the internet, it will attempt to connect to the internet time server to obtain the time. Once the connection succeeds and the console's time has updated, the SYNC icon **SYNC** will appear on the LCD. The time will automatically synchronize to the internet per an hour.

 **Note: Time synchronize method: Synchronized through internet UTC time server.**

11. Register with WeatherCloud.net

Note: This is best done on a computer desktop or laptop.

Visit : <https://weathercloud.net/> and enter a Username, Email and Password *(It is your Login password of the website, It not your email password. So no privacy will be exposed).*

11.1. Sign Up

1) Click Sign up as below

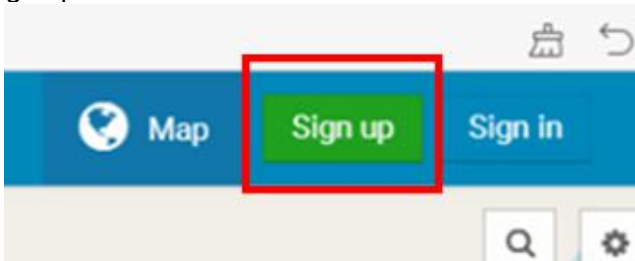

Figure 17

2) As shown below, enter a Username, Email and Password then Click Sign up.

A screenshot of the WeatherCloud.net sign-up form. At the top left, there is a blue header with the WeatherCloud logo and the text 'weathercloud'. Below the header, the text 'Join Weathercloud' is displayed. The form consists of three input fields: a text field for the username containing 'uct5', an email field containing '*****@qq.com', and a password field containing '*****'. Below the input fields is a blue button with the text 'Sign up'. At the bottom of the form, there is a small line of text: 'By clicking Sign up, you agree to our Terms of Service and Privacy Policy.'

Figure 18

3) As shown below, an email will be received in your registered mailbox .

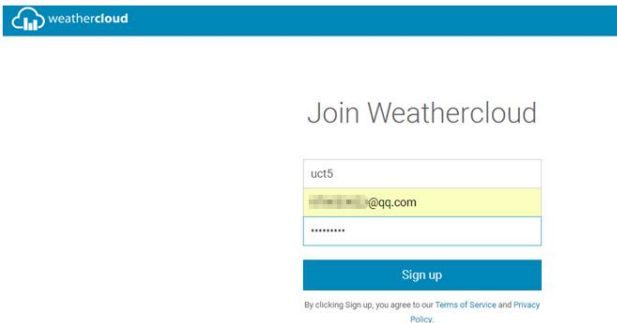
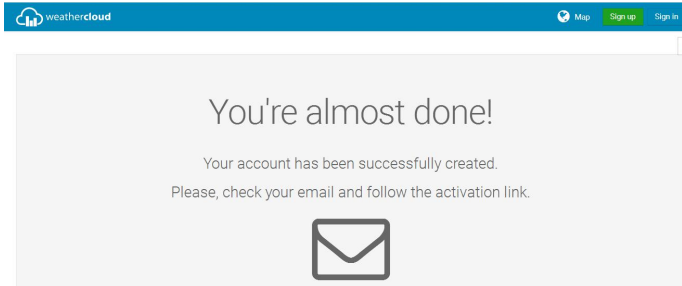

Figure 19

4) As shown below, open your mail and log in to the Web address in the mail.



Figure 20

5) As shown below, click “here” to enter the homepage of the weathercloud website.

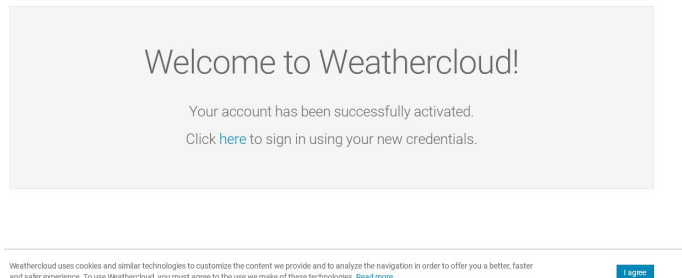
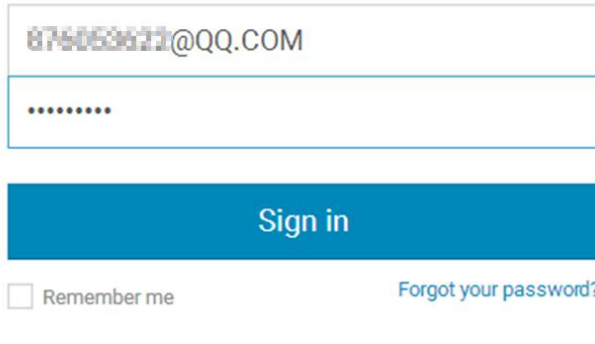

Figure 21

6) As shown below, enter the email address and password you just registered to enter the weathercloud website.

Sign in



875053623@QQ.COM

.....

Sign in

Remember me [Forgot your password?](#)

Not a member yet? [Sign up for free.](#)

Figure 22

11.2. Add a weather station device (it may take a few minutes).

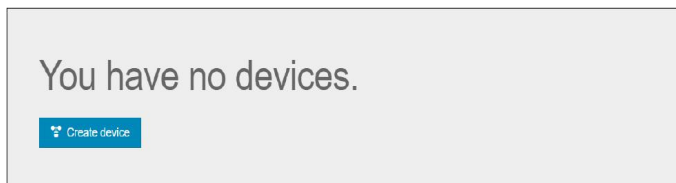

You have no devices.

[Create device](#)

Figure 23

1) After sign up you will be prompted to add a device/ Select “Create device” and enter your station’s information:
Blanks with red * must be filled in.

Name *	<input type="text" value="FT0835"/>	Country *	<input type="text" value="Hong Kong"/>
Model *	<input type="text" value="Ultimeter 100 Series"/>	State / Province *	<input type="text" value="Hong Kong"/>
Link type *	<input type="text" value="Weather Display"/>	City *	<input type="text" value="Hong Kong"/>
Website	<input type="text" value="www.example.com"/>	Time zone *	<input type="text" value="(UTC+08:00) Hong Kong"/>
Description	<input type="text"/>		
	<input type="button" value="Get coordinates"/>		
	Latitude *	<input type="text" value="23.241346102386135"/>	
	Longitude *	<input type="text" value="118.125"/>	
	Elevation *	<input type="text" value="0.0"/> m	

Figure 24



Note: You can select any Model number and Link type in the above blanks.

2) As shown below, click Get coordinates to identify your location of on the map, then click Done to confirm..

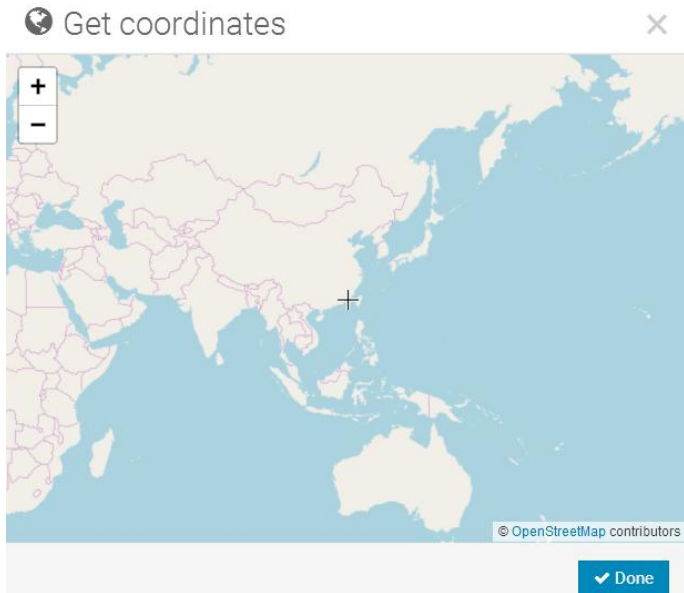

Figure 25

3) As shown below, click Create.

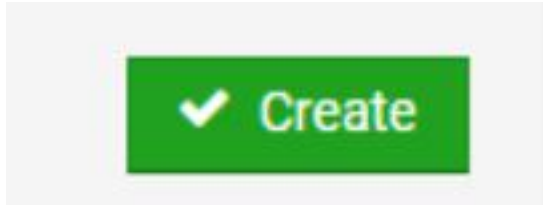

Figure 26

4) As shown below, after registering successfully, please record the Weathercloud ID and Key information for later use. (Refer to 13.6)

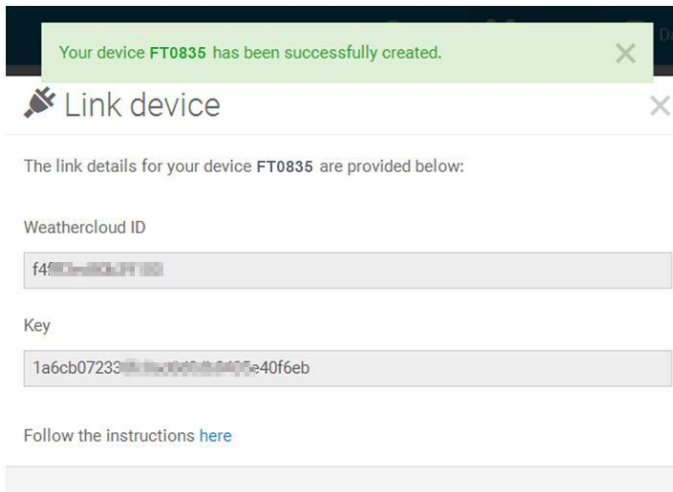



Figure 27

12. Register at Wunderground.com (Weather Underground)

 **Note:** The Weather Underground website is subject to change. Visit: <https://Wunderground.com>, and select the Join link in the upper right and corner and create a Free Account.

1) as shown below, Click Join

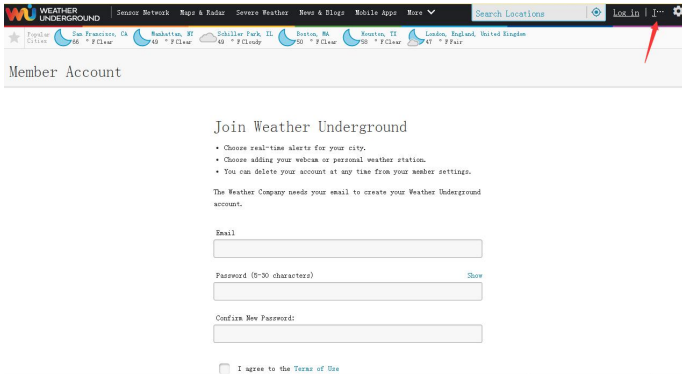

Figure 28

2) As shown below, enter a Username, Email and Password (**It is your Login password of the website, It not your email password. So no privacy will be exposed.**). Click Sign up for free.

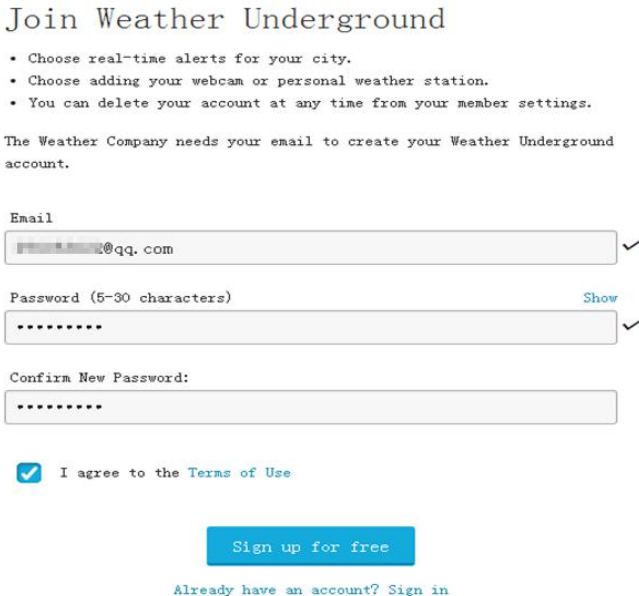

Figure 29

3) As shown below, registration is done successfully.

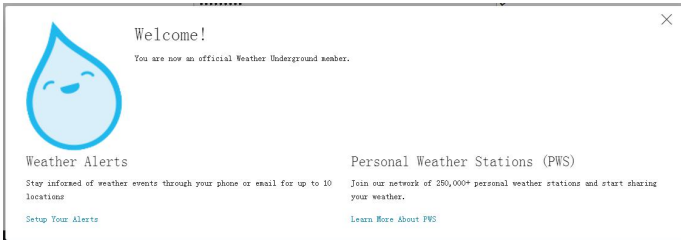

Figure 30

4) As shown below, click Log in and enter the email address and password you just registered.

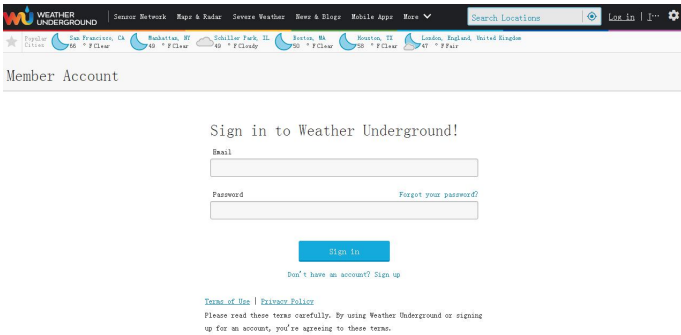

Figure 31

5) As shown in the below, click My Profile. Then enter Member Settings.

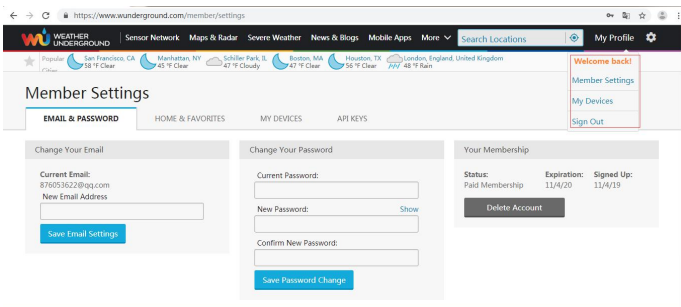

Figure 32

6) As shown below, click Update home location.

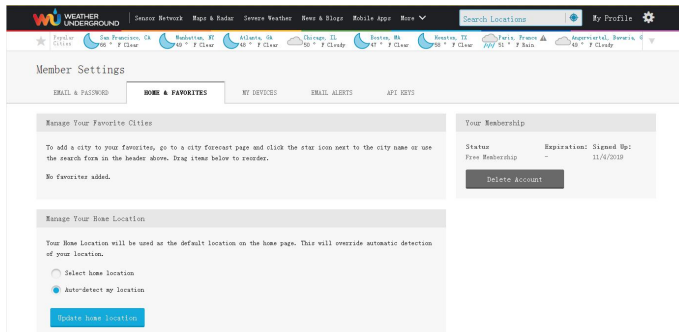

Figure 33

7) As shown below, you will then be prompted to add a device/ Select "Add New Device"

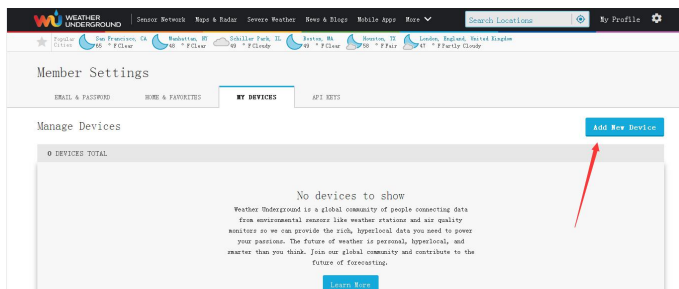

Figure 34

8) As shown below, click Personal Weather Station.

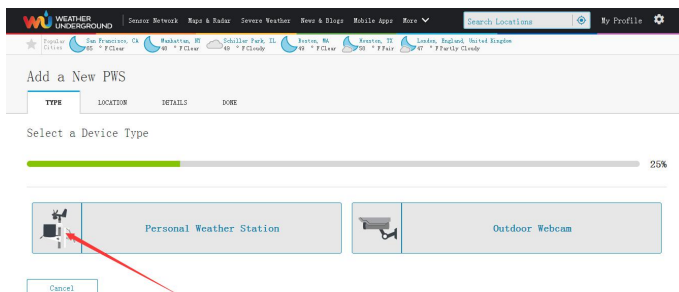

Figure 35

9) As shown below, select Address by inputting an address or select Manual to position your address automatically. Then click Next:

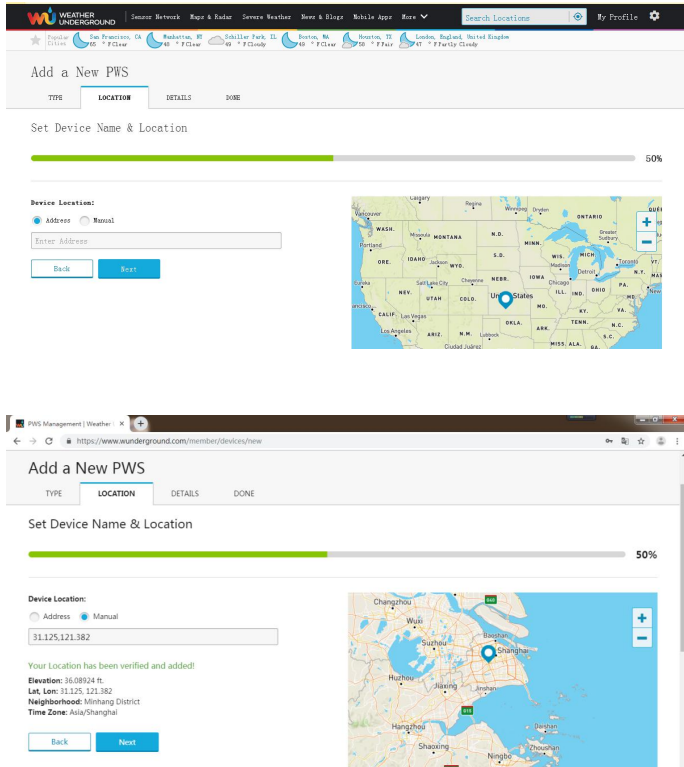

Figure 36

10) As shown below, you will then be prompted to add a device/ Select “Create device”, then click I Accept and Next: Blanks with red (Required) must be filled in.



Note: You can select any wifi weather station model in Device Hardware blank.

Name:

Surface Type:

Elevation:

Associate Wireless:

Device Hardware:

- Airmax 150w Ultrasonic
- Airmax 200w Ultrasonic
- AcuSite 3-in-1 Weather Station with Wi-Fi
- AcuSite 3-in-1 Weather Station with Wi-Fi
- AcuSite 3-in-1 Weather Station with AcuSite Access
- AcuSite 3-in-1 Weather Station with AcuSite Access
- AcuSite 3-in-1 Weather Station with Wi-Fi
- AcuSite Basic Weather Station with Wi-Fi
- AcuSite Basic Weather Station with AcuSite Access
- AcuSite Pro Weather Center
- AcuSite Weather WS-4022S
- AcuSite Weather WS-4025S
- AcuSite Weather WS-1100 (Wireless)
- AcuSite Weather WS-1101 (Wi-Fi) (Wireless)
- AcuSite Weather WS-1102 (Wi-Fi) (Wireless)
- AcuSite Weather WS-1108 (IP) (Wireless)
- AcuSite Weather WS-1109 (IP) (Wireless)
- AcuSite Weather WS-2000
- AcuSite Weather WS-2000 (Wireless)

Height Above Ground:

You Make Our Forecasts More Accurate. We Respect Your Privacy

Contribute to the Weather Underground community by sharing some information about yourself and your sensor. We use this information to manage your account and to improve the experience from the Weather Underground community. We may also share certain data for commercial purposes, such as your sensor location.

[Learn more about how we take your privacy seriously](#)

(Required)

I Accept I Deny

Email Preferences:

I would like to receive PWS notifications.

Figure 37

11) As shown below, after registering the host successfully, please record Station ID and Station Key information for later use (refer to 13.6).

Registration Complete! 100%

Congratulations! Your personal weather station is now registered with Weather Underground.

Enter the information below to your weather station software.

Your PWS:

Station ID: **#####G**

Station Key: **#####T00a**



Configure Your Software

Figure 38

12) As shown below, registration is done successfully.

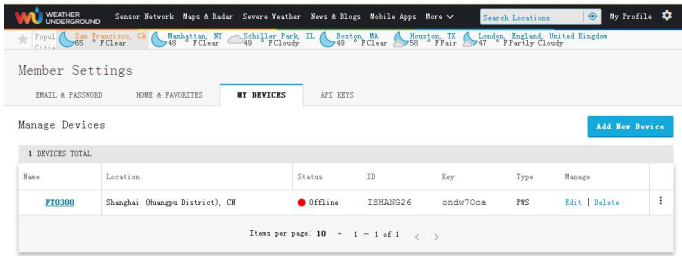



Figure 39

13. WiFi Setup(Connect your Device to the Console's WiFi)



Note:WIFI connection must use adapter

When you first power up(AC) the console, or press and hold the **MIN/MAX/-** button for three seconds in normal mode, the console icon(In front of the Indoor Temperature)  will flash to signify that it has entered WAP (wireless access point) mode, and is ready to enter for WiFi settings.

You can use your desktop, laptop, tablet, or smart phone to connect to the console's WiFi. The console's network name begins with WeatherHome, followed by a unique code.

Note that when the console programming is complete, you will resume your default WiFi connection.

Note that you cannot connect two or more devices at the same time when WAP mode.

13.1:Example 1: Connect to the console WiFi server with a PC. Choose WiFi network settings from Windows (or search "Change Wi-Fi Settings" from Windows), and Connect to the WeatherHome WiFi network, as shown in Figure 40 (your WiFi network name may be slightly different, but will always begin with WeatherHome).

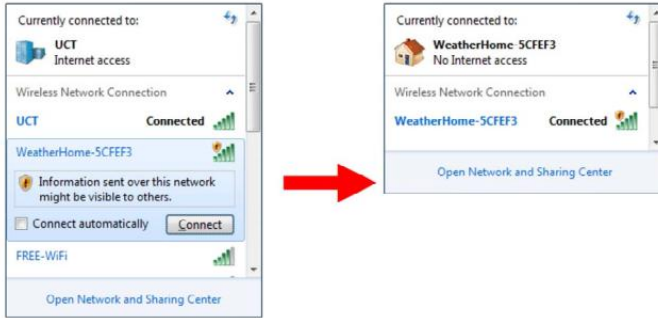



Figure 40

13.2: Example 2. Connect to the console WiFi server with a Mac.

Choose the Settings icon  and  Network . Connect to the WeatherHome WiFi network, as shown in Figure 41 (your WiFi network name may be slightly different, but will always begin with WeatherHome).

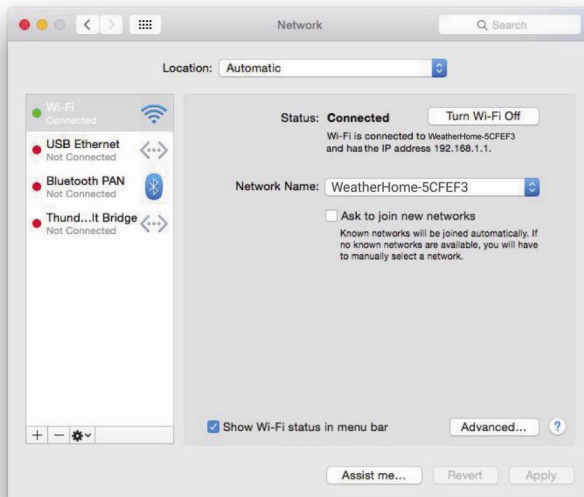

Figure 41

13.3: Example 3. Connect to the console WiFi server with an iPhone or iPad.



Choose the Settings icon  and Wi-Fi. Connect to the WeatherHome WiFi network, as shown in Figure 42 (your WiFi network name may be slightly different, but will always begin with WeatherHome).



Figure 42

13.4: Example 4. Connect to the console WiFi server with an Android device.

From the Apps icon, choose the Settings icon  and Wi-Fi. Connect to the WeatherHome WiFi network, as shown in Figure 43 (your WiFi network name may be slightly different, but will always begin with WeatherHome).

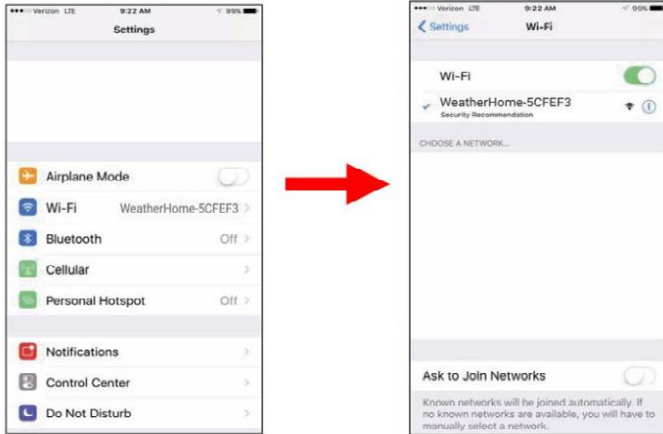

Figure 43

13.5. Once connected, enter the following IP address into any browser's address bar:<http://192.168.5.1> to access the console's web interface.



Note: Some browsers will treat 192.168.5.1 as a search, so make sure you include the header <http://>, or: <http://192.168.5.1> not 192.168.5.1

13.6. Enter the following information into the web interface (Figure 44). Make sure all of the information is entered prior to selecting Save. If you choose not to upload Wunderground.com, or upload weathercloud.net, leave the check boxes unchecked.

http://192.168.5.1/ → Into browser's address bar: <http://192.168.5.1>

Sainlogic Weather Setup

→ Web interface Logo

Wi-Fi network setup

Network → Select your WiFi Router (SSID) from the list

Password → Router's password

Status: Connected, IP: 192.168.1.111 → Check to connected IP status if saved setting

Weather server setup

Upload wunderground.com → Check to confirm upload to Weather underground server

ID → Enter Your Station ID

Password → Enter Your Station Key / Password

Upload weathercloud.net → Check to confirm upload to weathercloud.net

ID → Enter Your Weathercloud ID

Key → Enter Your Weathercloud Key / Password

Time Zone Setup

Time Zone → Time Zone Settings

Automatically adjust clock for Daylight Saving Time → DST on/off

Internet Time Server Setup

Server → Internet time server

→ Press Save to confirm the setting

Figure 44

Note: Hidden SSIDs. If you have a hidden SSID, enter the SSID manually.

Time Zone Settings(default: 0h). based on the number of hours from Coordinated Universal Time, or Greenwich Mean Time (GMT). The following table provides times zones throughout the world. Locations in the eastern hemisphere are positive, and locations in the western hemisphere are negative.

Hours from GMT	Time Zone	Cities
-12	IDLW: International Date Line West	---
-11	NT: Nome	Nome, AK
-10	AHST: Alaska-Hawaii Standard CAT: Central Alaska HST: Hawaii Standard	Honolulu, HI
-9	YST: Yukon Standard	Yukon Territory
-8	PST: Pacific Standard	Los Angeles, CA, USA
-7	MST: Mountain Standard	Denver, CO, USA
-6	CST: Central Standard	Chicago, IL, USA
-5	EST: Eastern Standard	New York, NY, USA
-4	AST: Atlantic Standard	Caracas
-3	---	São Paulo, Brazil
-2	AT: Azores	Azores, Cape Verde Islands
-1	WAT: West Africa	---
0	GMT: Greenwich Mean WET: Western European	London, England
1	CET: Central European	Paris, France
2	EET: Eastern European	Athens, Greece
3	BT: Baghdad	Moscow, Russia
4	---	Abu Dhabi, UAE
5	---	Tashkent

Hours from GMT	Time Zone	Cities
6	---	Astana
7	---	Bangkok
8	CCT: China Coast	Beijing
9	JST: Japan Standard	Tokyo
10	GST: Guam Standard	Sydney
11	---	Magadan
12	IDLE: International Date Line East NZST: New Zealand Standard	Wellington, New Zealand

13.7. If all of the information you entered is correct press save to confirm(Figure 45). If it does not, check your web interface information again.







Figure 45

13.8. Once the setup is completed, disconnect your device from the console WiFi. Otherwise, the console will automatically exit WAP mode. (Figure 46)



Figure 46

If the connection is successful, the Wi-Fi console's status Wi-Fi icon  will stop flashing and remain on.

 **NOTE:** When the console successfully connects to your any website of weather servers, the data signal icon  will appear on the LCD display(In front of the Indoor Temperature). If the data signal icon  is flashing, the console is currently uploading to the server. If the icon  disappears, the console is not connected to the weather server for more than 30 minutes.

13.9. Viewing your Data on Weather Underground

Visit:<http://www.wunderground.com/personal-weather-station/dashboard?ID=STATIONID>
where STATIONID is your personal station ID (example, KCALOSAN782).

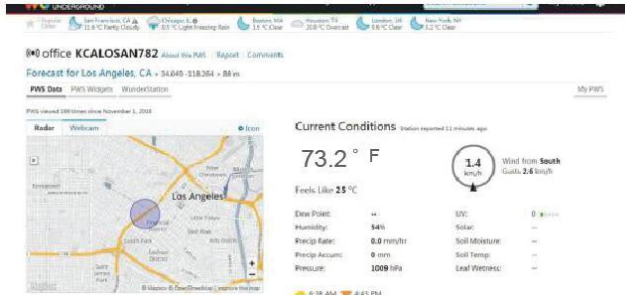



Figure 47

 **Note:** The current temperature and humidity data is the Integrated Outdoor Transmitter.

13.10. View your data on Weathercloud.

Visit the website www.weathercloud.net and sign in with your e-mail address and password. Then you will go to the weather data of your weather station automatically.

14. Upgrade firmware

You may get the latest firmware of the console as below

14.1. When you first power up(AC) the console, or press and hold the MIN/MAX/(WiFi) button for three seconds in normal mode, the console

icon(behind the In/Outdoor humidity)  will flash to signify that it has entered WAP (wireless access point) mode, and is ready to enter for WiFi settings.

14.2. Use your smart phone, tablet, or computer to connect to the console through WiFi(reference: **Example 1-4 of WiFi Setting**).

14.3. Once connected, enter the following IP address into the browser's address bar: <http://192.168.5.1/upgrade.html>



Figure 48

14.4. Once connection succeeds, it will jump to “Upload Setting” screen automatically.



Figure 49

14.5. Press Select File key to select the upgraded firmware as figure 50.

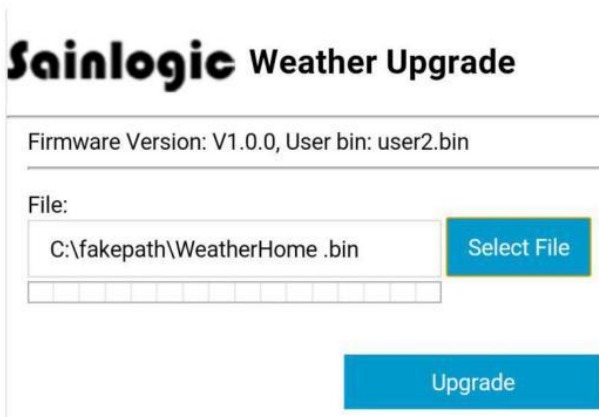

Figure 50

14.6. If update successfully when press Upgrade key. Then you will see the following.

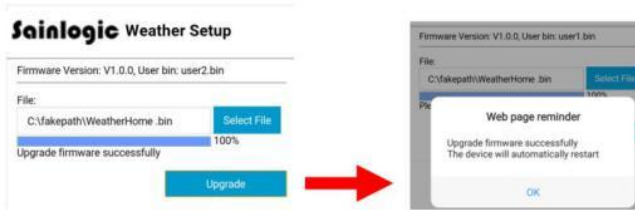



Figure 51

 **Note:** In this upgrade only Wifi firmware is updated. The console does not reset.

14.7. Once the upgrade is completed, the console will automatically exit WAP mode.

15. Other Console Features

The following section describes additional features and display icons.

15.1. Weather Forecasting

 **Note:** The weather forecast or pressure tendency is based on the rate of change of barometric pressure. In general, when the pressure increases, the weather improves (sunny to partly cloudy) and when the pressure decreases, the weather degrades (cloudy to rain).

The weather forecast is an estimation or generalization of weather changes in the next 24 to 48 hours, and varies from location to location. The tendency is simply a tool for projecting weather conditions and is never to be relied upon as an accurate method to predict the weather.

15.2. Weather Icons

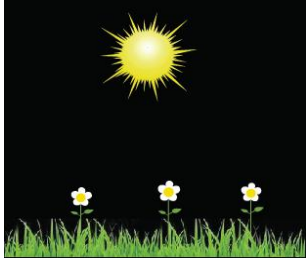
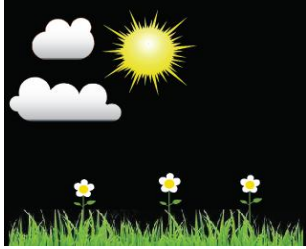
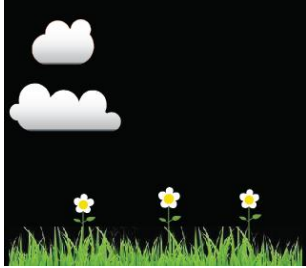
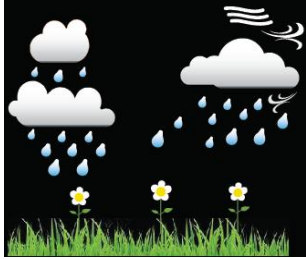
Condition	Icon	Description
Sunny		<p>Pressure is rising and the previous condition is partly cloudy.</p>
Partly Cloudy		<p>Pressure is falling and the previous condition is sunny or Pressure is rising and the previous condition is cloudy.</p>
Cloudy		<p>Pressure is falling and the previous condition is partly cloudy or Pressure is rising and the previous condition is rainy.</p>
Rainy		<p>Pressure is falling and the previous condition is cloudy.</p>

15.3. Moon Phase

The following moon phases are displayed based on the calendar date.

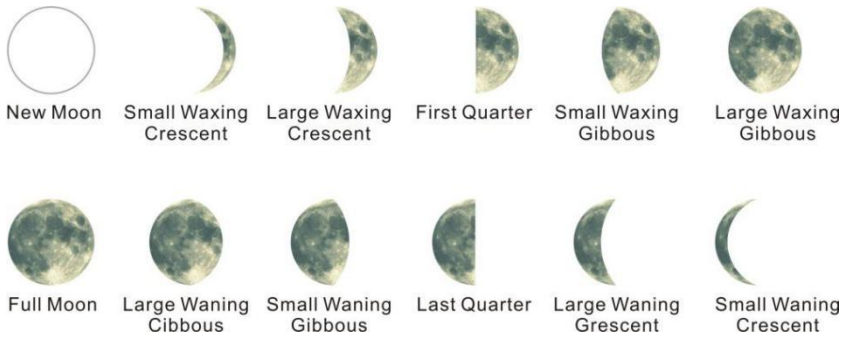

Figure 52

15.4. Pressure Threshold Setting

The pressure threshold (the negative or positive rate of change of pressure signifying a change in the weather) can be adjusted from 2 mbar/hour to 4 mbar/hour (default level 2 mbar/hour).

The lower the level pressure threshold setting, the higher sensitivity for weather forecast changes. Locations that experience frequent changes in air pressure require a higher setting compared to locations where the air pressure is typically stagnant.

15.5. Feels Like Temperature

Feels like temperature is a combination of Heat Index and Wind Chill.

At temperatures less than 40°F, the wind chill is displayed, as shown in the National Weather Service Wind Chill Table below:



NWS Windchill Chart

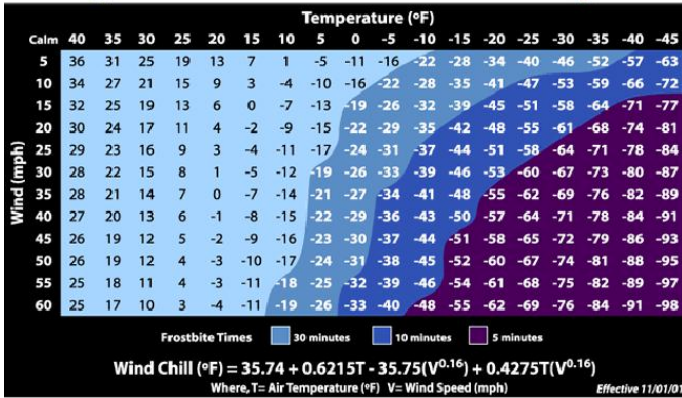

Figure 53

At temperatures greater than 80°F, the heat index is displayed, as shown in the National Weather Service Heat Index Table below:

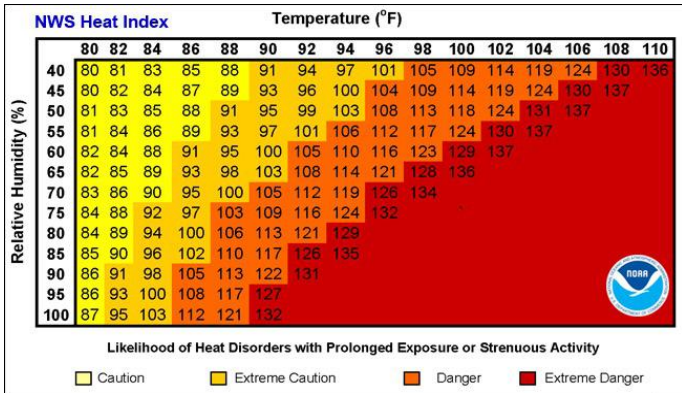

Figure 54

When the temperature is between 40°F and 80°F, the OUT temperature is displayed (Feels Like temperature is the same as OUT temperature).

16.Specifications

16.1. Wireless Specifications

- Line of sight wireless transmission (in open air): 300 ft.
- Frequency: 433 MHz
- Integrated Outdoor transmitter interval: 16 seconds

16.2. Measurement Specifications

The following table provides specifications for the measured parameters.

Measurement	Range	Accuracy	Resolution
Indoor Temperature	32 to 140 °F	± 2 °F	0.1 °F
Outdoor Temperature	-40 to 140 °F	± 2°F	0.1 °F
Indoor Humidity	10 to 99 %	± 5% (only guaranteed between 20 to 90%)	1 %
Outdoor Humidity	10 to 99%	± 5% (only guaranteed between 20 to 90%)	1 %
Rain	0 to 396in	<0.6in: ±0.04in, 0.6in to 396in: ±7%	<39.4in (0.012in) >39.4in (0.04in)
Wind Direction	0 - 360 °	± 10° (16 point compass)	± 1° (16 point compass)
Wind Speed	0 to 112mph	4.5 mph ~22.4mph: ±6.7mph, 22.4mph ~112mph: ±10% (whichever is greater)	0.1mph
Barometric Pressure:	8.85 to 32.50 inHg	± 0.08 inHg	0.01 inHg

16.3. Power Consumption

- Base station (display console) : 3 x AAA 1.5V Alkaline or Lithium batteries (not included)
- Adaptor: 6V~ 500mA (included)
- Integrated Outdoor Transmitter: 3xAA alkaline batteries or Lithium batteries (not included)
Minimum 12 months for Integrated Outdoor Transmitter. The primary power source is the solar panel. The batteries provide backup power when there is limited solar energy

16.4. WiFi Specifications

1. WiFi Standard: 802.11 b/g/n
2. WiFi Console RF Frequency: 2.4 GHz
3. Setup User Interface (UI) support setup device: Build-in WiFi with WAP mode smart device, including laptops, computers, smart phones and smart pads.
4. Recommend web browser for setup UI: Web browser support of HTML 5, such as the latest versions of Chrome, Safari, IE, Edge, Firefox or Opera.
5. Line of sight WiFi RF transmission (in open air): 80 feet

17. Maintenance

1. Clean the rain gauge and wind transmitter once every 3 months.
 - Unscrew the rain collector funnel by turning it 30° counter clockwise.
 - Gently remove the rain collector funnel.
 - Clean and remove any debris or insects.
 - Install the collector funnel after it has been cleaned and completely dried.



Figure 55

A: Remove the rain collector funnel.



Figure 56

B: Install the collector funnel.



Figure 57

2. Replace the wind, rain and thermo-hygrometer transmitter batteries once every 1-2 years

18. Troubleshooting Guide.

Problem	Solution
<p>Wireless remote not reporting in to console.</p> <p>There are dashes (---) on the display console.</p>	<p>If any of the sensor communication is lost, dashes (---) will be displayed on the screen. To reacquire the signal, press and hold the CHANNEL/+ button for 3 seconds, and the remote search icon ☺ will be constantly displayed. Once the signal is reacquired, the remote search icon ☺ will turn off, and the current values will be displayed.</p> <p>The maximum line of sight communication range is 300 ft and 100ft under most conditions. Move the sensor assembly closer to the display console.</p> <p>If the sensor assembly is too close (less than 4.9ft), move the sensor assembly away from the display console.</p>

	<p>Make sure the remote sensor LCD display is working and the transmitter light is flashing once per 60 seconds.</p> <p>Install a fresh set of batteries in the remote thermo-hygrometer. For cold weather environments, install lithium batteries.</p> <p>Make sure the remote sensors are not transmitting through solid metal (acts as an RF shield), or earth barrier (down a hill).</p> <p>Move the display console around electrical noise generating devices, such as computers, TVs and other wireless transmitters or receivers.</p> <p>Move the remote sensor to a higher location. Move the remote sensor to a closer location.</p>
Indoor and Outdoor Temperature do not agree	<p>Allow up to one hour for the sensors to stabilize due to signal filtering. The indoor and outdoor temperature sensors should agree within 4 °F (the sensor accuracy is ± 2 °F).</p> <p>Use the calibration feature to match the indoor and outdoor temperature to a known source.</p>
Indoor and Outdoor Humidity do not agree	<p>Allow up to one hour for the sensors to stabilize due to signal filtering. The indoor and outdoor humidity sensors should agree within 10 % (the sensor accuracy is ± 5 %).</p> <p>Use the calibration feature to match the indoor and outdoor humidity to a known source.</p>
Display console contrast is weak	<p>Replace console batteries with a fresh set of batteries.</p>

<p>WiFi does not display on console.</p>	<p>Check your router for problems.</p> <ol style="list-style-type: none"> 1. Check WiFi symbol on the display. If wireless connectivity is successful the WiFi icon  will be displayed in the time field. 2. Make sure your modem WiFi settings are correct (network name, and password). 3. Make sure the console is plugged into AC power. The console will not connect to WiFi when powered by batteries only. 4. The console only supports and connects to 2.4 GHz routers. If you own a 5 GHz router, and it is a dual band router, you will need to disable the 5 GHz band, and enable the 2.4 GHz band. <p>The console does not support guest networks.</p>
<p>Data not reporting to www.wunderground.com or www.weathercloud.net</p>	<ol style="list-style-type: none"> 1. Confirm your password or key is correct. It is the password you registered on Wunderground.com. Your Wunderground.com password cannot begin with a non-alphanumeric character (a limitation of Wunderground.com, not the station). Example, \$worknet is not a valid password, but worknet\$ is valid. 2. Confirm your station ID is correct. 3. Make sure the date and time is correct on the console. If incorrect, you may be reporting old data, not real time data. 4. Make sure your time zone is set properly. If incorrect, you may be reporting old data, not real time data. <p>Check your router firewall settings. The console sends data via Port 80.</p>

Manufacturer:

Sainlogic High Tech Innovation Co.,LTD
F9,De Zhong Industrial Park,
Li Pu Street,Shenzhen,China
Post:518001
Phone:+86 755 80759871
www.sainlogic.com
Email:info@sainlogic.com
FCC ID :2ALHJ-WS0835